

## API 6A TYPE 6BX 2000 PSI BLIND FLANGES

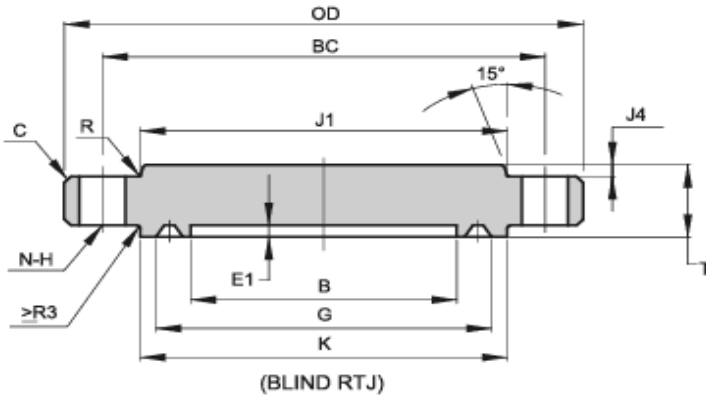

Size	OD	C	E1	G	K	T	J1	J4	R	BC	N	H	BX
26 3/4"	1040	6	21.4	768.3	805	126.3	835.8	9.7	16	952.5	20	48	167
30"	1120	6	23	862.3	908	134.2	931.9	17.5	16	1040	32	45	303

**Note:**

1. RING NUMBER BX,
2. C should be the max value
3. Tolerance and Ring Gasket according to API 6A-20TH